



ROUND SHAPES

LEGO isn't a medium inherently suited to building round shapes. After all, it's a system based on a regular square grid that consists primarily of rectangular elements. Despite this, there are many wonderful LEGO creations that feature organically curving forms. In this chapter, we'll look at some techniques for building round shapes like cylinders, circular walls, domes, and even spheres.

We'll also consider what's possible using LEGO's limited range of rounded elements, but our main focus will be on how to use regular bricks and plates to create the best possible approximation of a curve. The result is never perfect, and the limitations of the LEGO medium are always apparent in the jaggedness and gaps that you may see, especially when you look at your model up close. The trick is to create a convincing *illusion* of a round shape, at least when viewing your model from a few steps back.

CURVED LEGO ELEMENTS

The LEGO catalog includes a selection of round bricks, plates, and tiles. Specialized pieces are also available for creating round walls, hollow cylinders, and domes (see Figure 7-1). These pieces come in only a few different sizes, however, which limits the dimensions of the round structures you can build with them. For example, the biggest dome you can create using dome pieces has a diameter of 10 studs.

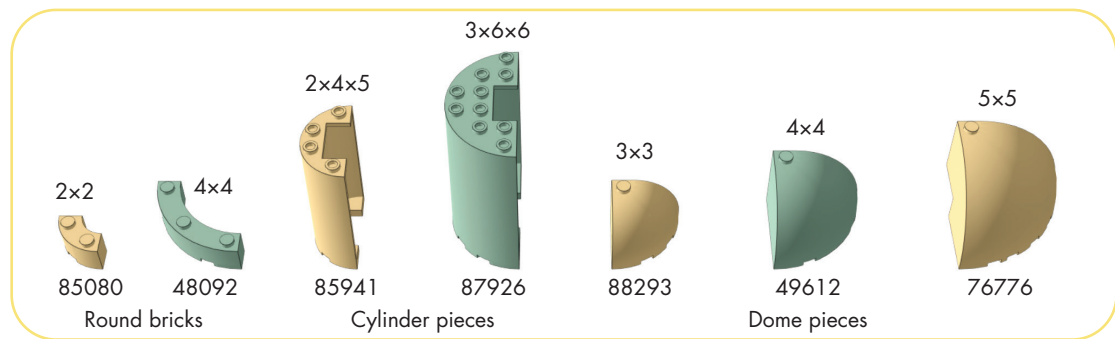

Figure 7-1: A selection of LEGO round bricks, cylinder pieces, and dome pieces

Another category of rounded LEGO elements is the curved slopes we first saw in Chapter 3. We can think of the sloped portion in a curved slope as the arc of a circle, and so technically, if we put enough of these pieces together, we should be able to form a circle. The tricky part is that we have to precisely position these pieces in different orientations. For that, we first need to use SNOT techniques to create a core that has studs facing in four different directions. We can then attach the curved slope pieces to the outside of this core to create a cylinder.

This approach is much more flexible than using LEGO's dedicated cylinder pieces, since you can achieve a wider variety of diameters (see Figure 7-2).

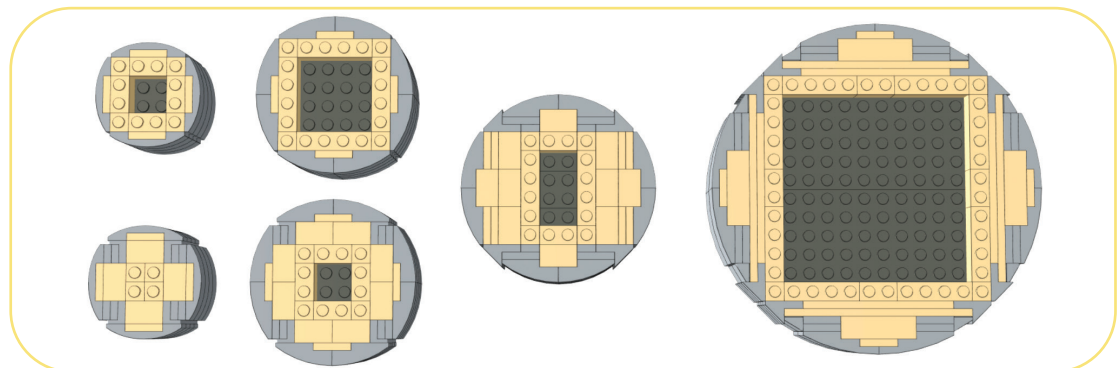

Figure 7-2: Cylinders created by attaching curved slope pieces to a SNOT core

The usual 6:5 ratio of sideways building applies, so the cylinder can be built up in height increments of 2 studs (or 5 plates).

The smallest of these cylinders consists of 1×4 curved slope pieces (#93273) attached on all four sides of a 4×4 square SNOT core. A 2×4 plate runs down the middle of each face of the core, filling in the gap on the underside of each slope piece and locking all the slopes into place (see Figure 7-3).

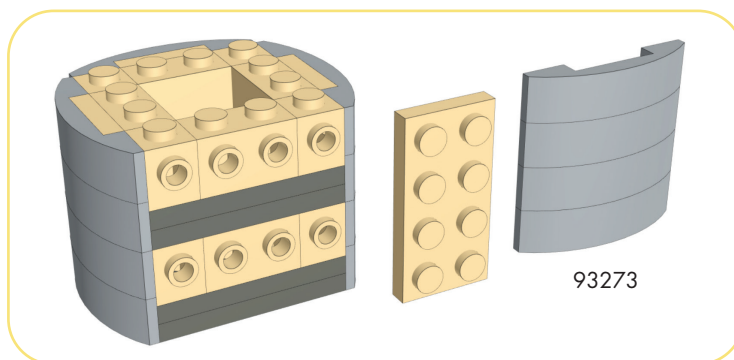

Figure 7-3: The smallest of the cylinders used for the minarets of the Taj Mahal

The result has a diameter of just under 6 studs, the perfect size for the minarets on my Taj Mahal MOC (Figure 7-4). These SNOT cylinders rely on curved slopes for their rounded form. For the rest of the chapter, however, we'll consider what round shapes are possible using primarily square and rectangular elements.

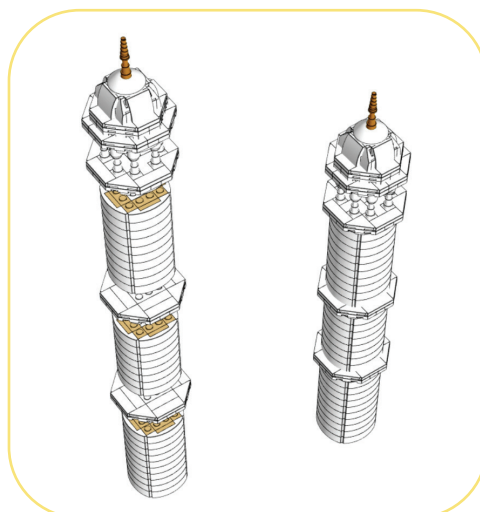

Figure 7-4: Taj Mahal minarets created by stacking cylinders

BUILDING ROUND WALLS

Round walls are an eye-catching addition to architectural builds. For example, you can use them to create a turret of a castle or a *tholobate* (also known as a *drum*), the cylindrical portion of a building beneath a dome. Let's look at a few different techniques for building round walls.

BENDING BRICKS

A brute-force approach to building a rounded wall is to build a straight wall using 1×2 bricks in a staggered bond pattern and then bend it to form a circle (see Figure 7-5). The longer your wall, the more flex it will have, making it easier for you to bend it into a complete circle. The number of 1×2 bricks needed in each layer to build a stable round wall tends to be around 72. The technique works with plates as well.

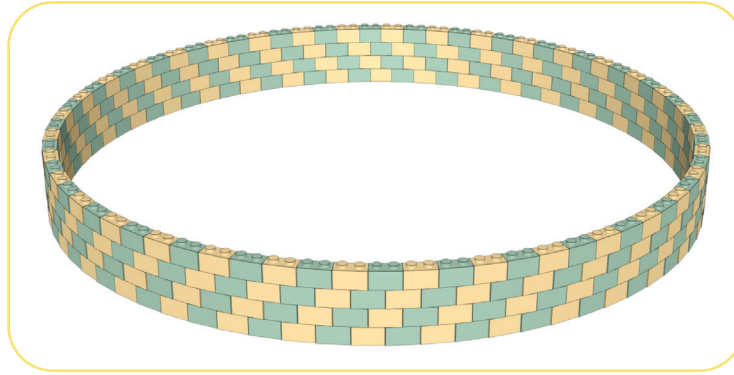

Figure 7-5: Bending a LEGO wall to create a round shape

LEGO artist Jeff Sanders specializes in art created using various *brick-bending* techniques like this. His amazing creations are made not just by bending LEGO walls into simple circles but also by interconnecting multiple curved wall segments to form intricate patterns. Strictly speaking, most brick-bending techniques are illegal because you're using LEGO elements in ways they aren't intended to be used and sometimes subjecting them to undue stress and possible damage. Another downside to this technique is that it can't easily be replicated digitally in Studio.

MIXING RECTANGULAR AND ROUND BRICKS

Another approach to building round walls is to alternate between rectangular bricks (1×3 or 1×2 bricks work well) and round 1×1 bricks in each layer. This technique is similar to brick bending, but the round bricks act like hinges, allowing the wall to be bent more easily (and legally!) into a circle. As illustrated in Figure 7-6, the method allows round walls to be built with smaller diameters than are possible with brick bending.

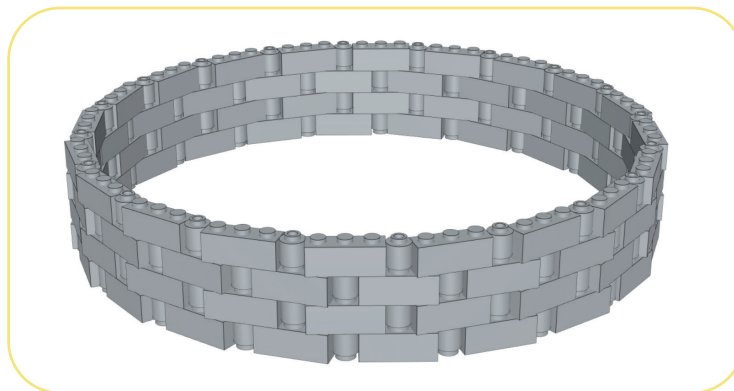

Figure 7-6: A round wall created by mixing 1×1 round bricks with regular 1×3 bricks

One downside to this technique is that the texture of the wall is uneven due to the 1×1 round bricks. However, it's possible to cover the outer surface of the wall with tiles to hide the round bricks, as seen in Figure 7-7.

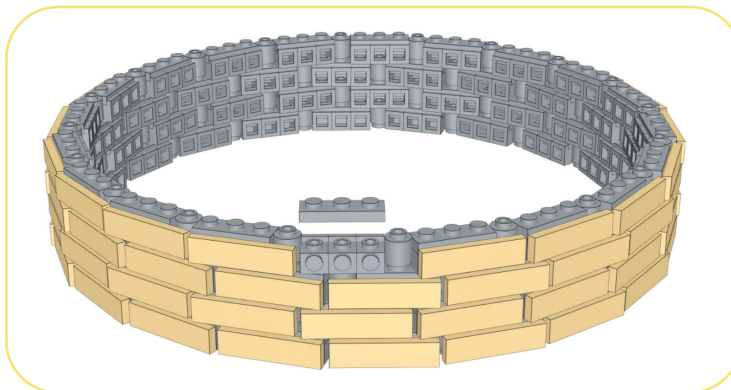

Figure 7-7: Using headlight bricks instead of 1×3 bricks allows 1×4 tiles to be attached to the outer surface of the wall.

Of course, adding the tiles requires SNOT building. Here I've replaced each 1×3 brick with three headlight bricks with their top studs facing out. These headlight bricks are joined together by a 1×3 plate to reach the full height of 1 brick. Meanwhile, the 1×4 tiles on the face of the wall mimic the look of real bricks, which should work great for castle builds.

USING HINGE PLATES

In Chapter 6, we discussed how to use LEGO hinge plates to create angled walls. If we extend this concept further, we should be able to create a continuous chain of angled wall segments, all of the same length, that come together to form a closed shape—that is, a *regular polygon*. Give that polygon enough sides (say, 20 or more), and it should pass for a circular wall.

SIMPLER POLYGONS

Let's first take a step back and see what it would take to build a simpler polygon, like a hexagon or an octagon. Then we'll apply what we've learned to making a circle. The challenge here is that it isn't enough to just build a polygonal structure using hinge pieces; we also need a way to incorporate it into a LEGO model by firmly attaching it to a baseplate. To make a good connection, we need at least one pair of opposite sides of the polygon to line up with the LEGO grid, even if the rest of the sides don't. For this reason, it's much easier to create polygons with an even number of sides.

Whether a pair of sides will align depends on the mathematical relationship between the length of each side of a regular polygon and the length of its *apothem* (the distance from the center of a polygon to the center of one of its sides—see the "Polygon Geometry" box for more information). What we need is a polygon where the side length is a whole number of studs, and where twice the apothem (the distance between two opposite sides) is also a whole number of studs—or close enough to a whole number, anyway.

POLYGON GEOMETRY

A *regular polygon* is a closed shape that has n sides of equal length, where n is 3 or greater. The point where any two adjacent sides intersect is called a *vertex*, and the line from a vertex to the center of a polygon is called the *radius*. As illustrated here, the angle between two adjacent radii is called the *central angle*. An n -sided polygon's central angle is equal to 360 degrees divided by n .

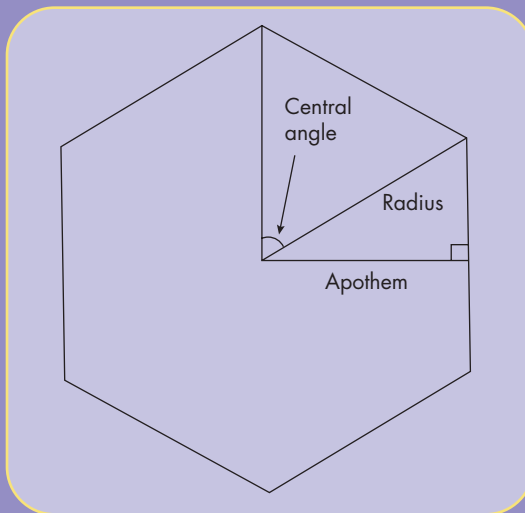

The *apothem* is a line drawn from the center of a polygon to the center point of one of its sides. This line is perpendicular to the side, and twice the apothem gives you the perpendicular distance between two opposite sides. A polygon's apothem is shorter than its radius, but these two lines combine with half a polygon's side to form a right triangle. So calculating the radius or apothem based on a polygon's side length is a simple matter of trigonometry. Or you can use an online tool to make the calculation for you!

Luckily, there are plenty of online apothem calculators that can help you figure out what side lengths will work for the polygon you're trying to build. Say you want to build a hexagon. Start plugging in different side lengths (2, 3, 4, 5, . . .) and you'll see that the shortest side length that yields (close to) a whole number for twice the apothem is 7 studs. The apothem for this hexagon is approximately 6 studs, making the distance between any pair of opposite sides about 12 studs. For an octagon, the smallest side length that works is 5 studs, and the distance between the opposite sides is, once again, around 12 studs. Figure 7-8 shows these two polygons, built with a mix of hinge plates and regular plates. Notice how the top and bottom sides of each polygon align with the LEGO grid.

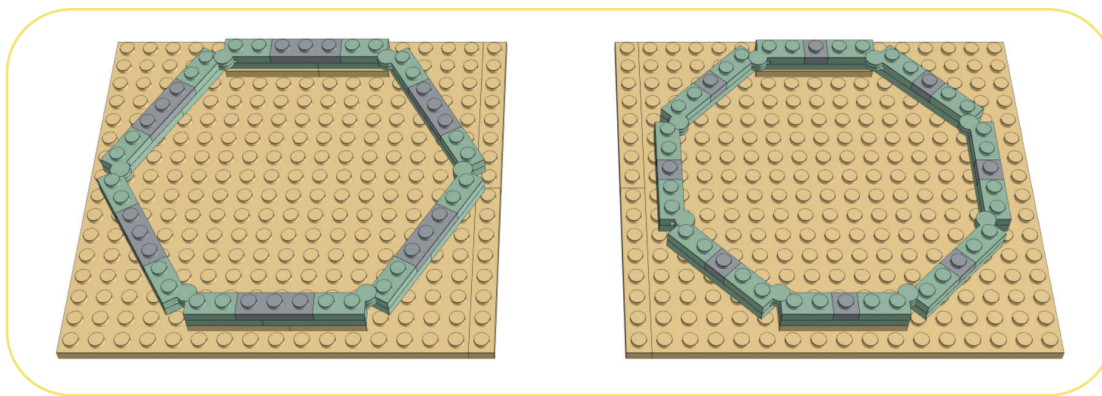

Figure 7-8: The smallest hexagon (left) and octagon (right) that can be securely attached to a LEGO baseplate

FROM POLYGONS TO CIRCLES

The same principle applies if we're trying to approximate a circle: one pair of opposite sides needs to align with the LEGO grid. To appear round, the polygon needs to have many sides, and each side should be quite short. The shortest we can go is a side length of 2 studs, achieved with two layers of 1×4 hinge plates. The hinge locations are offset by 2 studs between the layers, as shown in Figure 7-9.

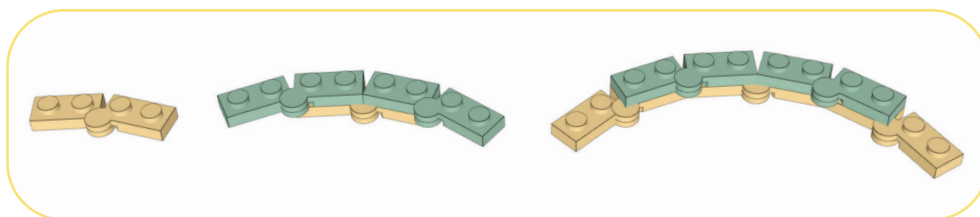

Figure 7-9: Building a round wall using two layers of hinge plates

We're holding the side length constant, but the number of sides (that is, the number of hinge plates) can vary based on the angle of each hinge. How many sides will work? A nice thing about a regular polygon with a large number of sides is that we can start thinking of its apothem as the radius of a circle, and twice the apothem as the circle's diameter. This lets us bypass apothem calculations and instead use the simpler formula $C = \pi d$, where C is the circle's circumference and d is its diameter. The circumference here (in studs) is the number of sides times 2, and dividing that by π gives us the diameter. If the diameter is close enough to a whole number, we'll be able to attach the round wall to a baseplate. Some side counts that work are 22 (diameter of 14 studs; see the left of Figure 7-10), 28 (diameter of 18 studs; see the right of Figure 7-10), 30 (diameter of 19 studs), and 36 (diameter of 23 studs; see the left of Figure 7-11).

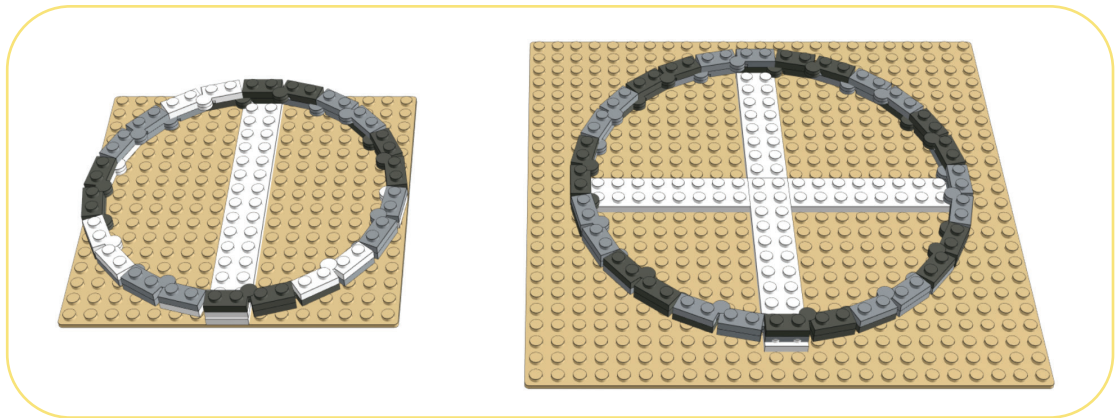

Figure 7-10: Round walls with diameters of 14 (left) and 18 (right) studs

Figure 7-11 shows how I used a round wall with a diameter of 23 studs to create the tholobate in my model of the Taj Mahal. I included a second ring of hinge plates near the top to better hold the individual sides together.

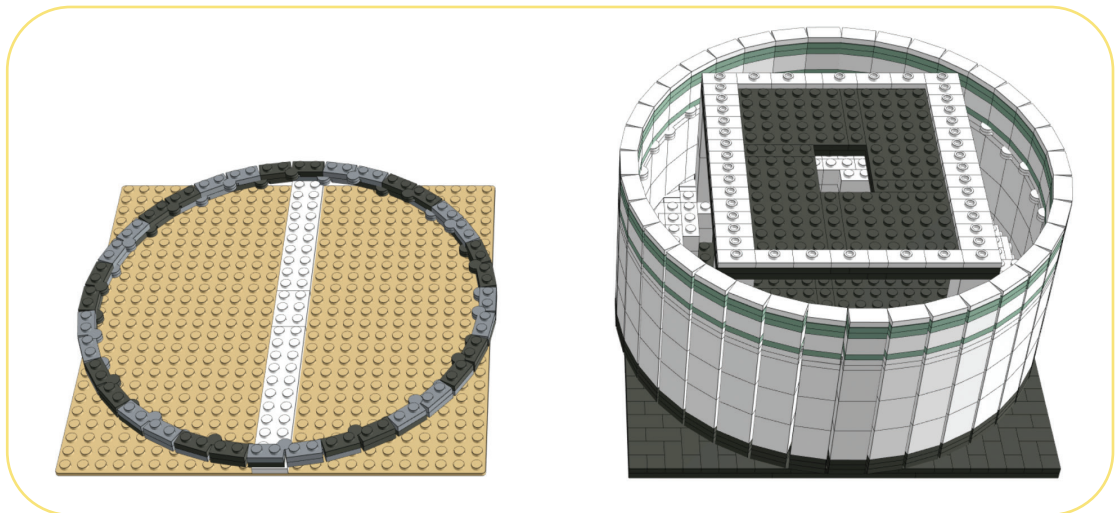

Figure 7-11: A round wall used for the tholobate (or drum) of the Taj Mahal

INTERNAL SUPPORT STRUCTURES

One issue you may encounter when using this technique is that it isn't easy to get the wall to keep its round shape. When there are just two connection points to the base, the rest of the hinged wall segments are free to move. There are ways to create an internal support framework using Technic elements, but it's simpler to build an inner wall using regular bricks as close as possible to the round wall. You can then use SNOT techniques to attach cheese slopes, curved slopes, and other elements to the inner wall, filling in the gaps and helping the outer wall retain its shape.

DIGITAL BUILDING TIP

In Chapter 6, we discussed how to rotate elements like hinge plates for angled building in Studio. The same technique applies to building a round wall digitally. The key is to make sure each hinge plate is rotated by just the right amount or else the two ends of the wall won't line up correctly and complete the circle. The angle of rotation necessary is the same as the central angle of the polygon. As mentioned in the "Polygon Geometry" box, this angle is equal to 360 divided by the polygon's number of sides. For a round wall with 28 sides (diameter of 18 studs), for example, the angle would be $360/28 = 12.85$ degrees. It's best to enter this angle manually (as described in Chapter 6). Each hinge assembly in the round wall needs exactly the same angle of rotation, so once you've rotated one hinge plate, copy and paste the hinge assembly (both halves together) as many times as needed to complete the circle.

BUILDING A SPHERE

A classic challenge in the LEGO world is using regular bricks and plates to get as close as possible to building a sphere. Spheres (or partial spheres) can have a wide range of applications in LEGO builds to create everything from a globe or a soccer ball to the dome of a building like the Taj Mahal.

STACKED BRICKS

One way to build a LEGO sphere is to stack layers of regular bricks, all with the studs facing up. Each layer is essentially an approximation of a circle. Start with the middle layer, the widest part of the sphere, and build out symmetrically from there, creating successively narrower "circles" above and below until you reach the top and bottom of the sphere. The question then becomes: For each layer of the sphere, how do you best approximate a circle?

APPROXIMATING A CIRCLE

It turns out LEGO builders aren't the only ones facing a dilemma in trying to create round forms out of square building blocks. The *Minecraft* community, too, has to navigate this challenge, and they've developed some resources that are readily adaptable to LEGO. For example, *Minecraft* enthusiasts often use a *circle chart* like the one shown in Figure 7-12.

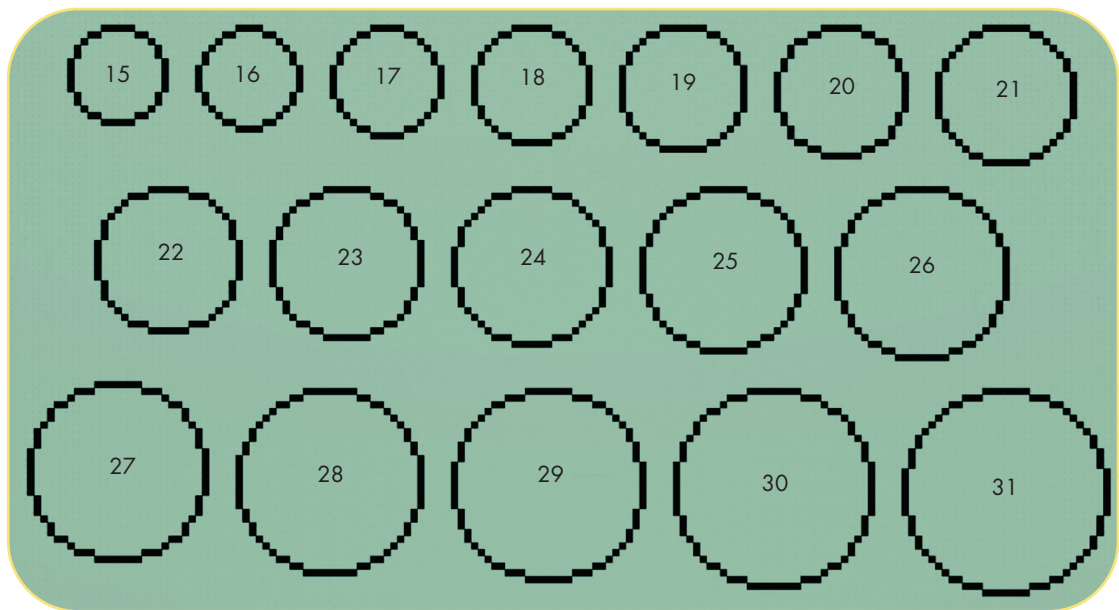

Figure 7-12: A *Minecraft* circle chart

A circle chart shows the best way to approximate a two-dimensional (2D) circle of various diameters by placing blocks (or pixels) in a square grid. The bigger the diameter, the more convincing is the illusion of the round shape. Consulting a chart like this, you could determine the ideal footprint of each layer of your LEGO sphere. Or, if that sounds a bit tedious, you can use Plotz (<https://www.plotz.co.uk>), an online 3D modeling assistant for *Minecraft*, to automate this process. With its Sphere tool, you just enter the sphere diameter you need, and presto, a sphere is generated for you, with 3D and 2D views showing how to build the sphere layer by layer (see Figure 7-13).

Getting from a Plotz model to an actual LEGO sphere still requires some thought. The sphere generator shows individual *Minecraft* blocks, the equivalent of 1×1 LEGO bricks, but you can't simply stack a bunch of 1×1 s the way you see in the 3D view. You need to convert the 1×1 s into longer bricks to form an interlocked structure that holds together well. You also need to make the walls of the sphere at least 2 studs deep, allowing each successive layer to rest on the layer immediately below it. Alternating the orientation of the bricks from one layer to the next, as discussed in Chapter 3, will yield the strongest result.

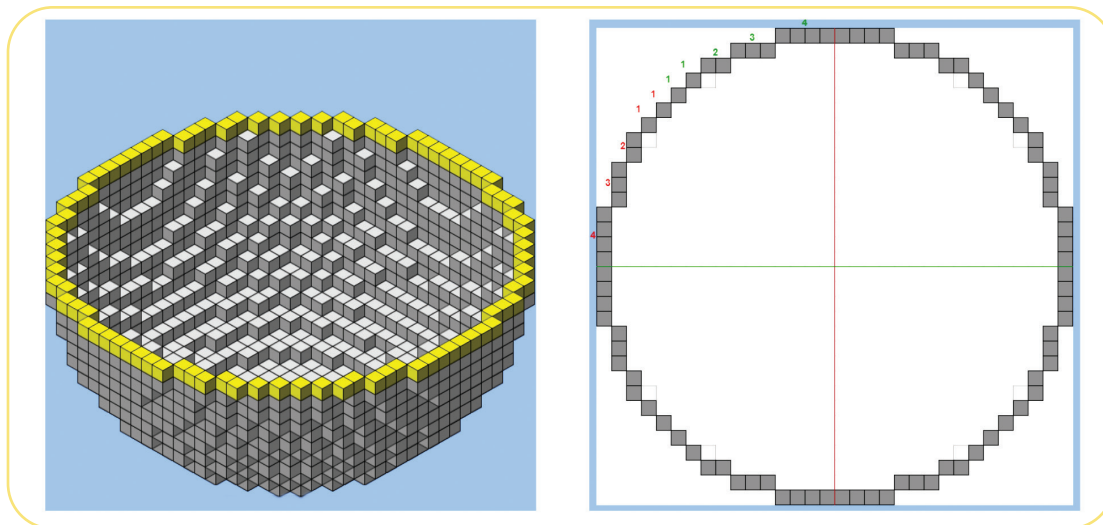

Figure 7-13: A sphere generated by Plotz, with a 3D and 2D view of the highlighted layer

MAINTAINING THE CORRECT PROPORTIONS

There's one last hitch. *Minecraft* blocks are perfect cubes, but 1×1 LEGO bricks, of course, are not. If you replace all the blocks in the Plotz model with LEGO bricks, your sphere will end up a little taller than it is wide—just like a 1×1 brick. Thankfully, Plotz also has an Ellipsoid tool, and you can use that to compensate for LEGO proportions. This tool lets you set the height, width, and depth of the 3D shape separately, as opposed to the single Size controller in the Sphere tool.

The key is to set the width and depth of the ellipsoid to your desired LEGO sphere diameter (in studs), and then set the height to five-sixths that diameter. For example, the left half of Figure 7-14 shows a Plotz ellipsoid with a width and depth of 24 units and a height of 20 units. The right half of the figure shows this ellipsoid translated into LEGO.

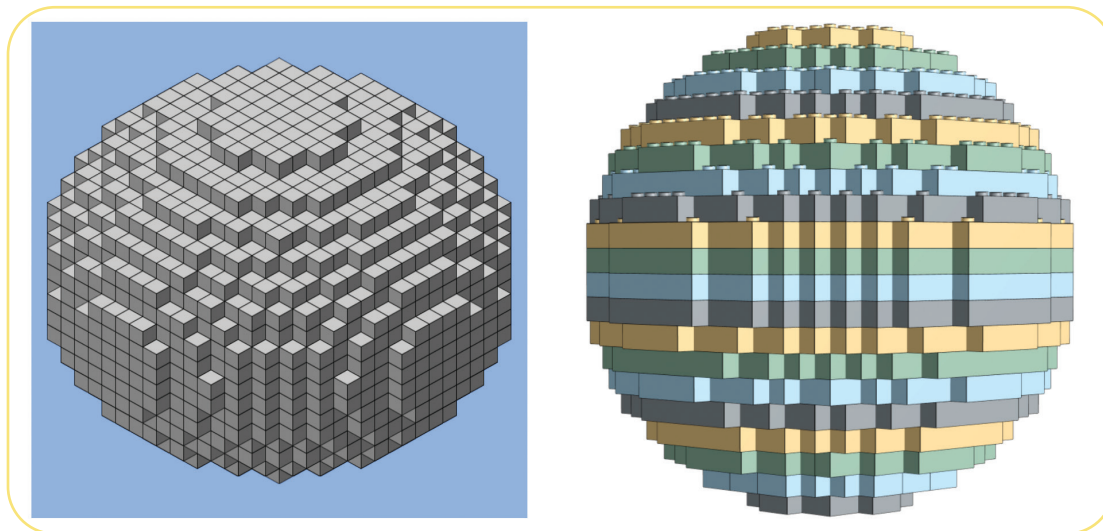

Figure 7-14: A Plotz ellipsoid (left) and the equivalent sphere built by stacking LEGO bricks (right)

Since a 1×1 brick has a height-to-width ratio of 6:5, the LEGO equivalent of a 5:6 ellipsoid works out to be perfectly spherical. The ratios cancel each other out.

STACKED PLATES

A sphere made from stacking bricks inevitably looks a little blocky. If we stack thinner LEGO plates rather than bricks, is it possible to smooth out the curves? To find out, we can go back to the Plotz ellipsoid generator and adjust the dimensions. Since a plate is one-third the height of a brick, a 1×1 plate has a height-to-width ratio of 2:5. The ellipsoid therefore needs to have the inverse ratio of 5:2. For example, if it's 24 units wide and deep, it should have a height of 60 units. Figure 7-15 shows the resulting LEGO sphere.

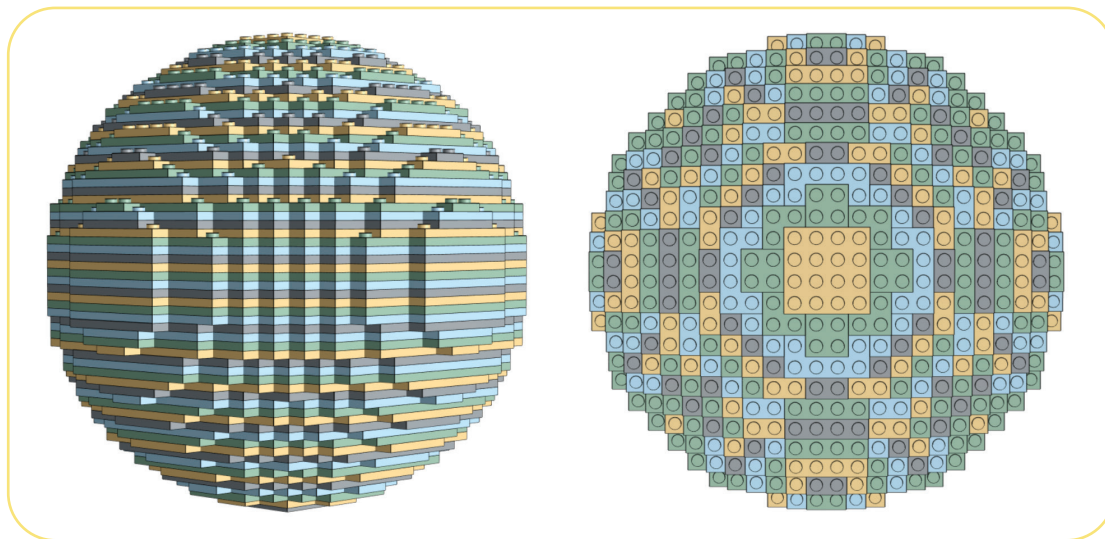

Figure 7-15: A sphere built by stacking LEGO plates

Looking at the sphere from the side, there's a definite improvement. The curves are less jagged thanks to the smaller height gradations achieved by using plates. But viewed from the top, the curves, once again, appear blocky. Plates still have the same basic footprint as bricks, so from the standpoint of width and depth, stacking plates is no better than before.

Furthermore, another downside to building spheres via simple stacking, whether it be bricks or plates, is that the undersides of the pieces will be visible when you view the sphere from below. Ideally, a sphere should have a uniform appearance no matter how it's oriented. To achieve that uniformity and smooth out the curves in all three dimensions, we need to turn to SNOT building.

LOWELL SPHERES

In 2002, Bruce Lowell revolutionized the construction of LEGO spheres by breaking them down into six identical curved panels built using LEGO plates. The panels are then joined together around an interior SNOT cube with studs in all six directions. Each panel is longer than it is wide, allowing the panels to interlock perfectly without any visible gaps and form a wonderfully smooth and symmetrical sphere. The result, known as a *Lowell sphere*, after its creator, is shown in Figure 7-16.

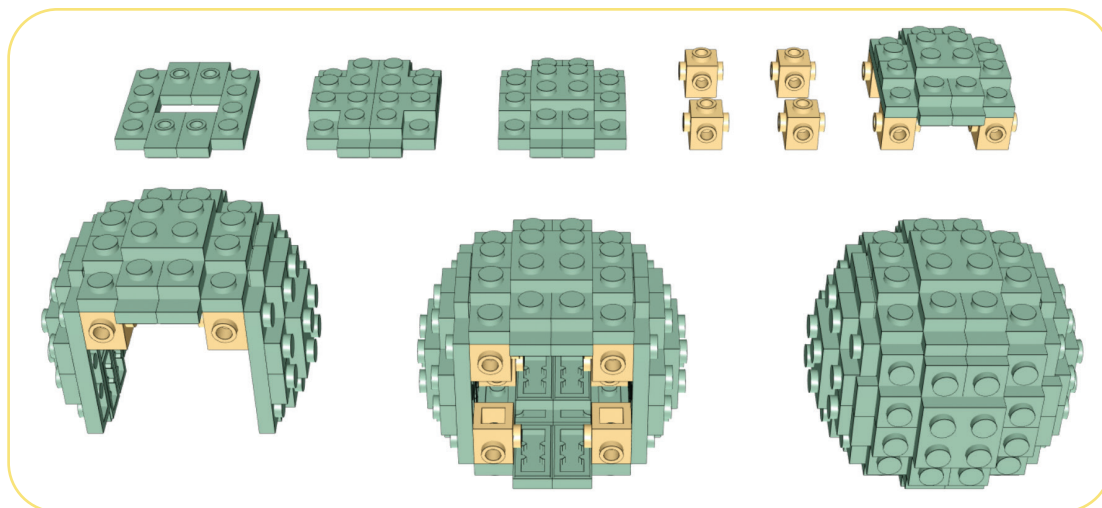

Figure 7-16: A basic Lowell sphere

Lowell's original sphere had a diameter of 6.8 studs and an inner $4 \times 4 \times 4$ core. Over time, the technique has been generalized to other dimensions. It's also found applications in sculpting complex shapes other than spheres, as we'll discuss in Chapter 9.

BRAM'S SPHERE GENERATOR

Much of the credit for the Lowell sphere's expansion goes to Bram Lambrecht and his online tool Bram's Sphere Generator (<https://lego.bl.design.org>). This tool can help you create a Lowell sphere with any diameter you need. Just enter the diameter (in increments of 0.2 studs) and tweak a few settings (such as whether to use jumper plates for even finer detail), and you're ready to save an LDraw file of a sphere, grouped into six panels, that can be imported into Studio. Figure 7-17 shows an example, with an individual panel on the left and the full sphere on the right.

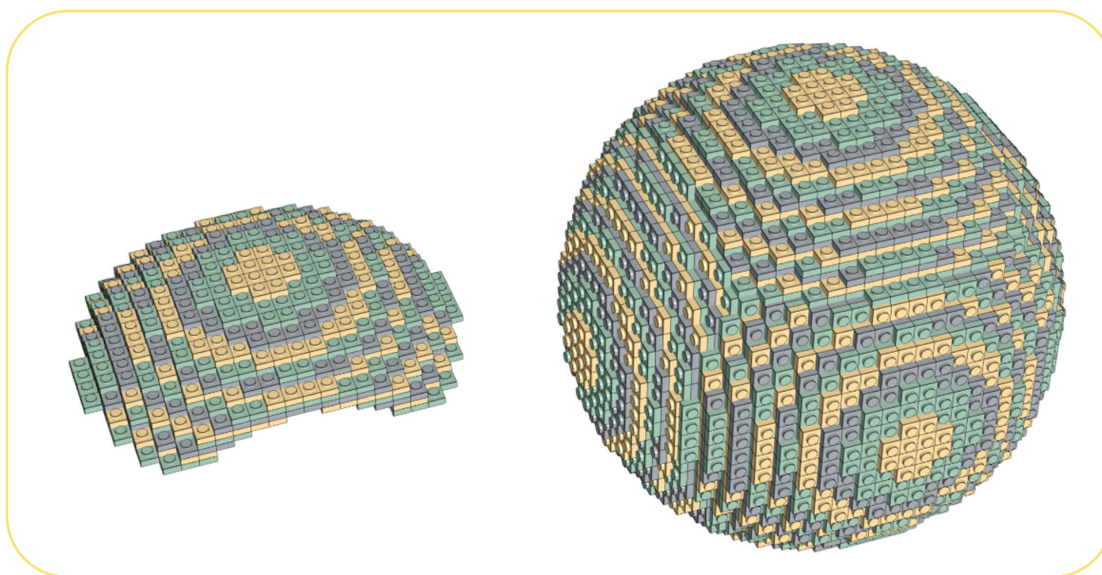

Figure 7-17: A bigger Lowell sphere

The resulting sphere is made entirely from 1×1 plates (plus 1×2 jumper plates if you've enabled that option). Therefore, as with consulting Plotz, there's still some manual work involved in realizing the sphere. You have to replace the 1×1 plates with bigger pieces that can interlock to hold each of the six panels together as a unit, ensuring that the seams between plates don't line up between successive layers of the panel. The Sphere Generator's Use Alternating Layer Colors option helps with this process, making it easy to see which layer is which.

The LDraw file also doesn't include a SNOT core, so you'll have to design that as well. You need a SNOT cube with studs in all six directions. Just a handful of connection points for each of the panels is usually sufficient.

DIGITAL BUILDING TIP

When you import an LDraw file from Bram's Sphere Generator into Studio, you'll notice that each of the six panels is considered a *submodel*. This is a collection of parts that have been grouped together and are treated as a unit. You can always break the submodel down into individual parts by right-clicking the submodel and selecting **Submodel ▶ Release** (selecting all the individual parts and clicking **Submodel ▶ Create** will re-create the submodel), but it is also possible to edit the submodel in place by selecting **Submodel ▶ Edit**.

All six panels are identical, so once you've created an interlocking design for one instance of the submodel, you can click **Return to Main Model** and see that all six copies of the submodel have been automatically updated.

MODIFIED SPHERES

With some modifications, Lowell spheres can be integrated into larger LEGO models as domes and other architectural features. For the rounded dome of my Taj Mahal model, for example, I started with a Lowell sphere with a diameter of 27.2 studs. It consisted of a 16×16×16 SNOT core and six 14-plate-thick curved panels. To turn this sphere into a dome, I removed the bottom panel entirely and reduced the height of the SNOT core by 2 studs.

Then I cropped the bottom portions of the four side panels to create a flat bottom surface and planned out a fully interlocking design for each panel (Figure 7-18).

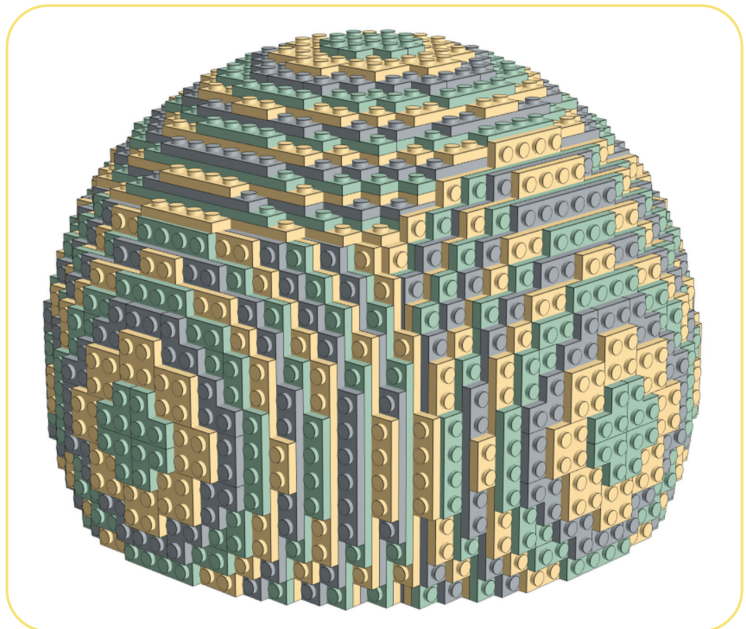

Figure 7-18: Truncating a Lowell sphere to form a dome

The panels on the front and back are oriented differently from the ones on the left and right. Truncating the bottom portions of all four at the same level yields two unique variants of the panels, one for the front and back and another for the left and right. Figure 7-19 shows the final dome of the Taj Mahal in the correct color scheme and with the decorative elements added on top, along with a breakdown of its various components.

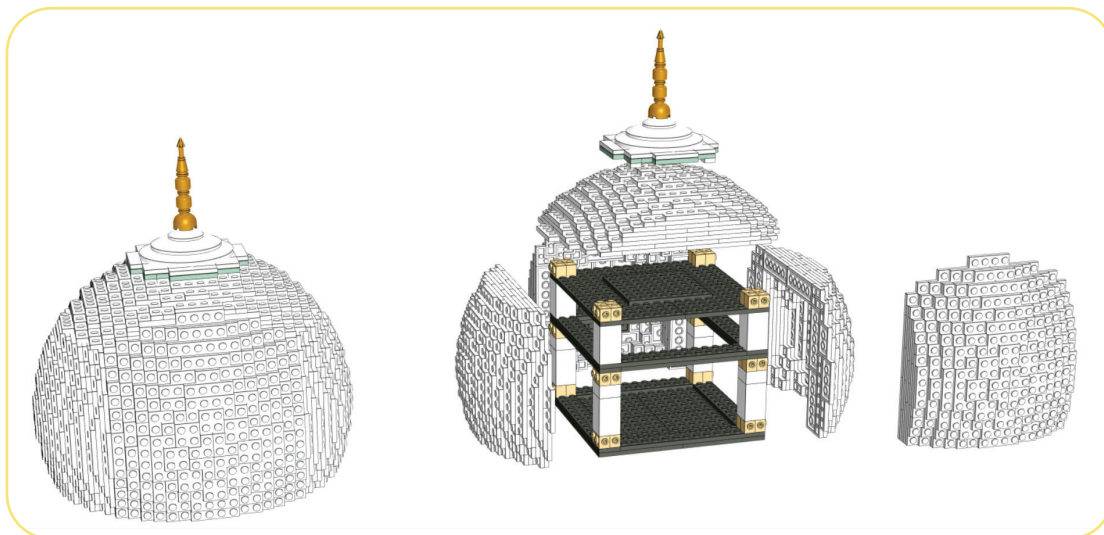

Figure 7-19: The dome of my Taj Mahal model

The bottom portion of the dome, which sits on the drum (shown in Figure 7-11), ended up having a diameter of $16 \text{ studs} + 22 \text{ plates} = 24.8 \text{ studs}$, very close to the drum's outer diameter of 25 studs.

SUMMARY

As you've learned in this chapter, you don't always need round bricks to create round LEGO shapes. It's possible to approximate round shapes with square (and rectangular) elements by using techniques like brick bending, hinged polygons, and Lowell spheres. This chapter also gave you a taste of how to use software tools like Bram's Sphere Generator to help plan LEGO builds. We'll continue to explore software-assisted building in the remainder of the book as we consider LEGO mosaics (Chapter 8) and sculptures (Chapter 9).